

XRC 50-30P (170kV)

PARCEL & BAGGAGE X-RAY IMAGING SYSTEM

The XRC 50-30P is a highly powerful, yet compact x-ray machine which provides exceptional ease in detecting threats, and offers unique image quality. Ideal for areas where space is a premium.

Compliant with
DFT
specification



Supplied & Serviced by
www.toddresearch.co.uk



XRC 50-30 (170kV)

TECHNICAL DATA



Supplied & Serviced by
www.todresearch.co.uk



PHYSICAL PROPERTIES

Tunnel Size	: 530mm x 330mm
(W x H)	: 20.86in x 12.99in
Dimensions	: 1265mm x 1150mm x 760mm
(LxHxW)	: 49.80in x 45.27in x 29.92in
Approx. Weight Unpacked	: 355kg (781lbs.)
Conveyor Height	: 700mm (27.55in)
Conveyor Load Capacity	: 165kg (364lbs.) Evenly Distributed
System Power	: 110/220V AC \pm 10%50/60 Hz, 5amp max.
Conveyor Speed	: 0.20 m/sec. Forward or Reverse

X-RAY GENERATOR & IMAGE PERFORMANCE

Steel Penetration	: 37mm guaranteed; 39mm typical
1 Wire Resolution	: 38 AWG guaranteed; 40AWG typical
1 Anode Voltage	: 170kV, operating at 147kV
Tube Current	: 0.7 mA
Beam Direction	: Vertically upward
Article Separation	: Low Z, Medium Z, High Z to 0.5 Z Accuracy
Cooling	: Oil and forced air cooling

COMPUTER SPECIFICATIONS

Processor	: Intel® Core™ i5 (or superior)
Monitor	: 21.5" Flat(or superior)
Memory	: 4 GB RAM (or superior)
Video Card	: 2 GB (or superior)
Hard Drive	: 1 TB (or superior)
USB Port	: 6 port (or superior)
Operating System	: Linux

OPERATING ENVIRONMENT

Storage / Operating Temperature	: -20°C to 50°C / 0°C to 40°C (-4°F to 122°F / 32°F to 104°F)
Relative Humidity	: 10% to 90% non-condensing

HEALTH AND SAFETY

All products supplied by Todd Research Ltd meet all applicable international health and safety regulations.
US FDA Federal Standard 21CFR 1020.40
Health and Safety at Work Act 1974-compliant 6 : Available
Film Safety : ISO 1600 / 33 DIN
CE Compliance : Certified
FCC & IEC Compatibility: Available
IP 20 Safety : Certified
Maximum level of radiation the exterior panels come in contact with is 0.1 mR/hour

OPTIONAL FEATURES

Barcode Reader System
External Camera Archiving
Remote Viewing Station
Recheck Station
Network Supervisory System (NSS)
Remote Access Connection
Smart Card Login

OPTIONAL EXTRAS

External UPS (For system)
Operator Console (Open-Closed/Adjustable/I-stand)
21.5"-27" Flat Monitor
Input/output Rollers
Test Kit (STP/ASTM)
Protective Cover
Search Table
Tray Return System (Motorized/Gravity)
Inclined Conveyor
Ultrasonic Rat Repellent
Radiation Meter
Virtual Threat Image Projection (TIP)
Threat Alarm

STANDARD IMAGE PROCESSING FEATURES

Perfect View (Detail Enhancement) (PV)
Edge Enhancement (EE)
Pseudo Colour (PS)
Organic Materials (OM)
Inorganic Materials (IM)
Black & White (B/W)
Inverse Colours (IN)
High Penetration (HP)
Variable Edge Enhancement (+E -E)
Variable Density (+D -D)
Variable Gamma (+G -G)
Variable Colour Separation (+C -C)
Zoom (64x)
Sniper Zoom
Recall Previous Images
Manual/Automatic Archive
Annotated Archive
Multi Energy Viewer (4 -6 Colour)
Atomic Number Display (Z Value)

STANDARD FEATURES

Programmable Function Keys
Parcel Counter
Date and Time Display
Operator Training Program (OTP)
UPS (For Computer Supply)
Multi Languages
Self Diagnosis
Generator Timer
Automatic Stop Conveyor

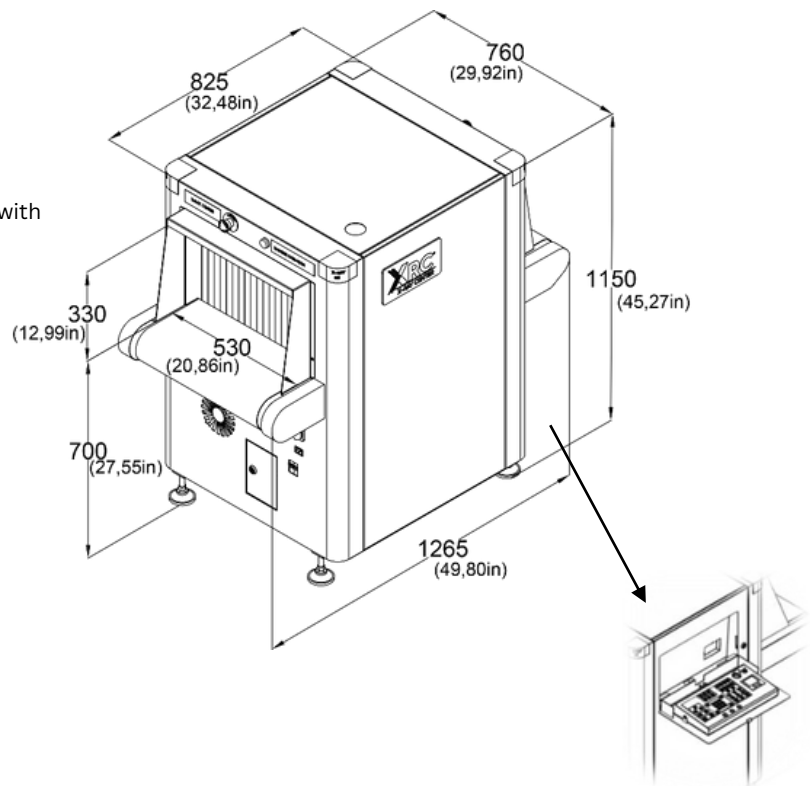

Todd Research Limited

9C Trafalgar Way | Bar Hill | Cambridgeshire | CB23 8SQ | UK

tel: +44 1480 832202

email: xray@todresearch.co.uk

