

# XRC 65-85

## PARCEL & BAGGAGE X-RAY IMAGING SYSTEM

The XRC 65-85 with a low conveyor unit, is ideal for scanning heavy loads with ease and convenience. This machine is equipped with advanced computer technology, the best-in-class software, and a range of image processing functions to further enhance the detection of potential threats.

Compliant with  
DfT  
specification



Supplied & Serviced by  
[www.toddresearch.co.uk](http://www.toddresearch.co.uk)



# XRC 65-85

## TECHNICAL DATA



Supplied & Serviced by  
www.todresearch.co.uk



### PHYSICAL PROPERTIES

|                         |                                       |
|-------------------------|---------------------------------------|
| Tunnel Size             | : 655mm x 865mm                       |
| (W x H)                 | : 26.18in x 34.06in                   |
| Dimensions              | : 3090mm x 1305mm x 1475mm            |
| (LxHxW)                 | : 121.65in x 51.38in x 58.07in        |
| Approx. Weight Unpacked | : 760kg (1676lbs.)                    |
| Conveyor Height         | : 290mm (11.42in)                     |
| Conveyor Load Capacity  | : 200kg (441lbs.) Evenly Distributed  |
| System Power            | : 110/220V AC ±10%50/60 Hz, 5amp max. |
| Conveyor Speed          | : 0.20 m/sec. Forward or Reverse      |

### X-RAY GENERATOR & IMAGE PERFORMANCE

|                    |   |
|--------------------|---|
| Steel Penetration  | : 37mm guaranteed; 39mm typical             |
| 1 Wire Resolution  | : 38 AWG guaranteed; 40AWG typical          |
| 1 Anode Voltage    | : 170kV, operating at 160kV                 |
| Tube Current       | : 1.0 mA                                    |
| Beam Direction     | : Horizontally sideward                     |
| Article Separation | : Low Z, Medium Z, High Z to 0.5 Z Accuracy |
| Cooling            | : Oil and forced air cooling                |

### COMPUTER SPECIFICATIONS

|                  |                                 |
|------------------|---------------------------------|
| Processor        | : Intel® Core™ i5 (or superior) |
| Monitor          | : 21.5" Flat (or superior)      |
| Memory           | : 4 GB RAM (or superior)        |
| Video Card       | : 2 GB (or superior)            |
| Hard Drive       | : 1 TB (or superior)            |
| USB Port         | : 6 port (or superior)          |
| Operating System | : Linux                         |

### OPERATING ENVIRONMENT

|                                 |  |
|---------------------------------|--|
| Storage / Operating Temperature | : -20°C to 50°C / 0°C to 40°C<br>(-4°F to 122°F / 32°F to 104°F) |
| Relative Humidity               | : 10% to 90% non-condensing                                      |

### HEALTH AND SAFETY

All products supplied by Todd Research Ltd meet all applicable international health and safety regulations.  
US FDA Federal Standard 21CFR 1020.40  
Health and Safety at Work Act 1974-compliant 6 : Available  
Film Safety : ISO 1600 / 33 DIN  
CE Compliance : Certified  
FCC & IEC Compatibility: Available  
IP 20 Safety : Certified  
Maximum level of radiation the exterior panels come in contact with is 0.1 mR/hour

### OPTIONAL FEATURES

Barcode Reader System  
External Camera Archiving  
Remote Viewing Station  
Recheck Station  
Network Supervisory System (NSS)  
Remote Access Connection  
Smart Card Login

### OPTIONAL EXTRAS

External UPS (For system)  
Operator Console (Open-Closed/Adjustable/I-stand)  
21.5"-27" Flat Monitor  
Input/output Rollers  
Test Kit (STP/ASTM)  
Protective Cover  
Search Table  
Tray Return System (Motorized/Gravity)  
Inclined Conveyor  
Ultrasonic Rat Repellent  
Radiation Meter  
Virtual Threat Image Projection (TIP)  
Threat Alarm

### STANDARD IMAGE PROCESSING FEATURES

Perfect View (Detail Enhancement) (PV)  
Edge Enhancement (EE)  
Pseudo Colour (PS)  
Organic Materials (OM)  
Inorganic Materials (IM)  
Black & White (B/W)  
Inverse Colours (IN)  
High Penetration (HP)  
Variable Edge Enhancement (+E -E)  
Variable Density (+D -D)  
Variable Gamma (+G -G)  
Variable Colour Separation (+C -C)  
Zoom (64x)  
Sniper Zoom  
Recall Previous Images  
Manual/Automatic Archive  
Annotated Archive  
Multi Energy Viewer (4 -6 Colour)  
Atomic Number Display (Z Value)

### STANDARD FEATURES

Programmable Function Keys  
Parcel Counter  
Date and Time Display  
Operator Training Program (OTP)  
UPS (For Computer Supply)  
Multi Languages  
Self Diagnosis  
Generator Timer  
Automatic Stop Conveyor

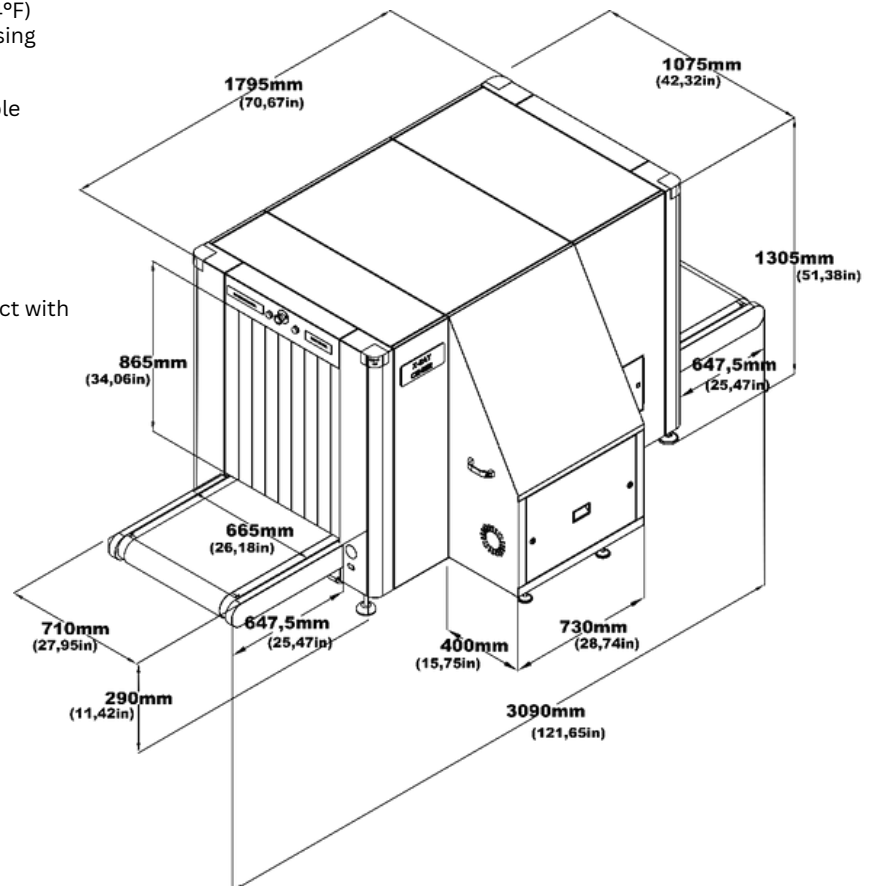

Todd Research Limited

9C Trafalgar Way | Bar Hill | Cambridgeshire | CB23 8SQ | UK

tel: +44 1480 832202

email: xray@todresearch.co.uk

