

# XRC 75-55

## PARCEL & BAGGAGE X-RAY IMAGING SYSTEM

The XRC 75-55 X-ray baggage scanner is an advanced security system that allows operators to easily detect potential threats. With the help of various image processing functions, hazard alarms, and state-of-the-art computer technology, this scanner is designed to reduce the rate of error and increase the accuracy of threat detection.

Compliant with  
DFT  
specification



Supplied & Serviced by  
[www.toddresearch.co.uk](http://www.toddresearch.co.uk)



# XRC 75-55

## TECHNICAL DATA



Supplied & Serviced by  
www.todresearch.co.uk



### PHYSICAL PROPERTIES

Tunnel Size	: 755mm x 555mm
(W x H)	: 29.72in x 21.85in
Dimensions	: 2180mm x 1480mm x 1030 mm
(LxHxW)	: 85.83 in x 58.27in x 40.55in
Approx. Weight Unpacked	: 635kg (1400lbs.)
Conveyor Height	: 810mm (31.89 in)
Conveyor Load Capacity	: 165kg (364lbs.) Evenly Distributed
System Power	: 110/220V AC $\pm$ 10%50/60 Hz, 5amp max.
Conveyor Speed	: 0.20 m/sec. Forward or Reverse

### X-RAY GENERATOR & IMAGE PERFORMANCE

Steel Penetration	: 37mm guaranteed; 39mm typical
1 Wire Resolution	: 38 AWG guaranteed; 40AWG typical
1 Anode Voltage	: 170kV, operating at 160kV
Tube Current	: 1.0 mA
Beam Direction	: Vertically upward
Article Separation	: Low Z, Medium Z, High Z to 0.5 Z Accuracy
Cooling	: Oil and forced air cooling

### COMPUTER SPECIFICATIONS

Processor	: Intel® Core™ i5 (or superior)
Monitor	: 21.5" Flat(or superior)
Memory	: 4 GB RAM (or superior)
Video Card	: 2 GB (or superior)
Hard Drive	: 1 TB (or superior)
USB Port	: 6 port (or superior)
Operating System	: Linux

### OPERATING ENVIRONMENT

Storage / Operating Temperature	: -20°C to 50°C / 0°C to 40°C (-4°F to 122°F / 32°F to 104°F)
Relative Humidity	: 10% to 90% non-condensing

### HEALTH AND SAFETY

All products supplied by Todd Research Ltd meet all applicable international health and safety regulations.  
US FDA Federal Standard 21CFR 1020.40  
Health and Safety at Work Act 1974-compliant 6 : Available  
Film Safety : ISO 1600 / 33 DIN  
CE Compliance : Certified  
FCC & IEC Compatibility: Available  
IP 20 Safety : Certified  
Maximum level of radiation the exterior panels come in contact with is 0.1 mR/hour

### OPTIONAL FEATURES

Barcode Reader System  
External Camera Archiving  
Remote Viewing Station  
Recheck Station  
Network Supervisory System (NSS)  
Remote Access Connection  
Smart Card Login

### OPTIONAL EXTRAS

External UPS (For system)  
Operator Console (Open-Closed/Adjustable/I-stand)  
21.5"-27" Flat Monitor  
Input/output Rollers  
Test Kit (STP/ASTM)  
Protective Cover  
Search Table  
Tray Return System (Motorized/Gravity)  
Inclined Conveyor  
Ultrasonic Rat Repellent  
Radiation Meter  
Virtual Threat Image Projection (TIP)  
Threat Alarm

### STANDARD IMAGE PROCESSING FEATURES

Perfect View (Detail Enhancement) (PV)  
Edge Enhancement (EE)  
Pseudo Colour (PS)  
Organic Materials (OM)  
Inorganic Materials (IM)  
Black & White (B/W)  
Inverse Colours (IN)  
High Penetration (HP)  
Variable Edge Enhancement (+E -E)  
Variable Density (+D -D)  
Variable Gamma (+G -G)  
Variable Colour Separation (+C -C)  
Zoom (64x)  
Sniper Zoom  
Recall Previous Images  
Manual/Automatic Archive  
Annotated Archive  
Multi Energy Viewer (4 -6 Colour)  
Atomic Number Display (Z Value)

### STANDARD FEATURES

Programmable Function Keys  
Parcel Counter  
Date and Time Display  
Operator Training Program (OTP)  
UPS (For Computer Supply)  
Multi Languages  
Self Diagnosis  
Generator Timer  
Automatic Stop Conveyor

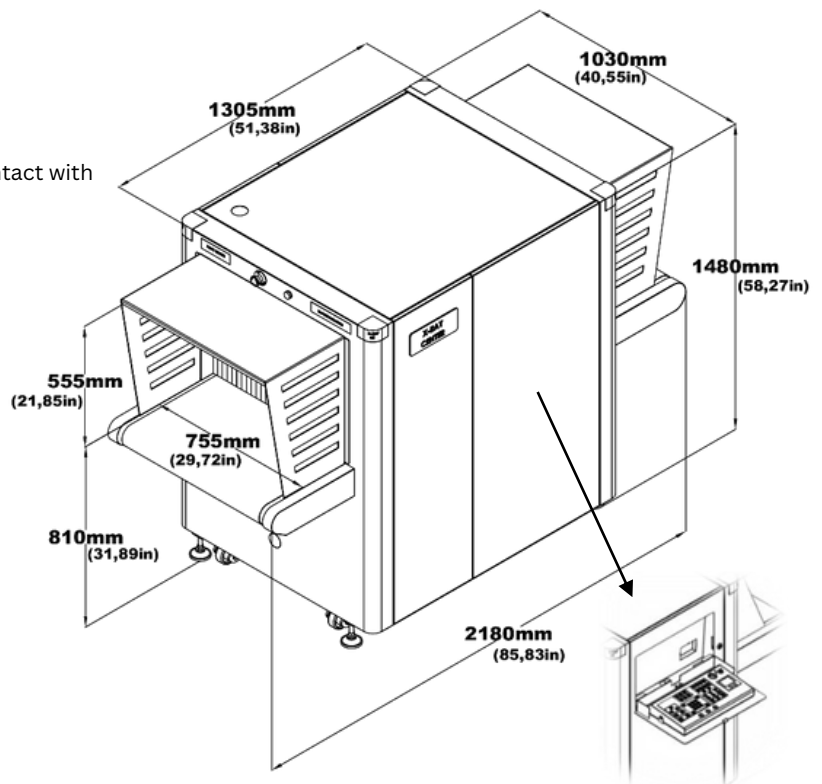

Todd Research Limited

9C Trafalgar Way | Bar Hill | Cambridgeshire | CB23 8SQ | UK

tel: +44 1480 832202

email: xray@todresearch.co.uk

